

- LESS GIVEAWAY – direct weighing ensures 20-30% less giveaway compared to traditional weighers
- VERY COMPETITIVE AND HEAVY DUTY SOLUTIONS – keep productivity high and costs down.
- LOWEST COST OF OWNERSHIP (COO) on the market

YOUR PRODUCTIVITY IS OUR CONCERN

Robust and reliable machines are key factors in your production - but costs are too. Our newest design for the dry food industry has become even more competitive, though still offering the most hygienic and smooth design on mar-ket. Our vibrator technology can be set to move almost any product carefully and efficiently, including difficult products such as sticky dried fruits or fragile cookies and candies.

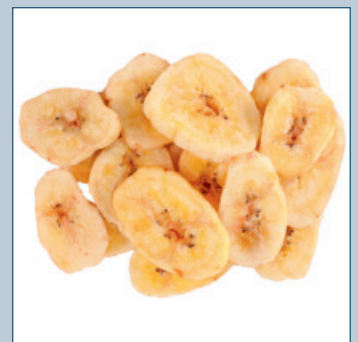
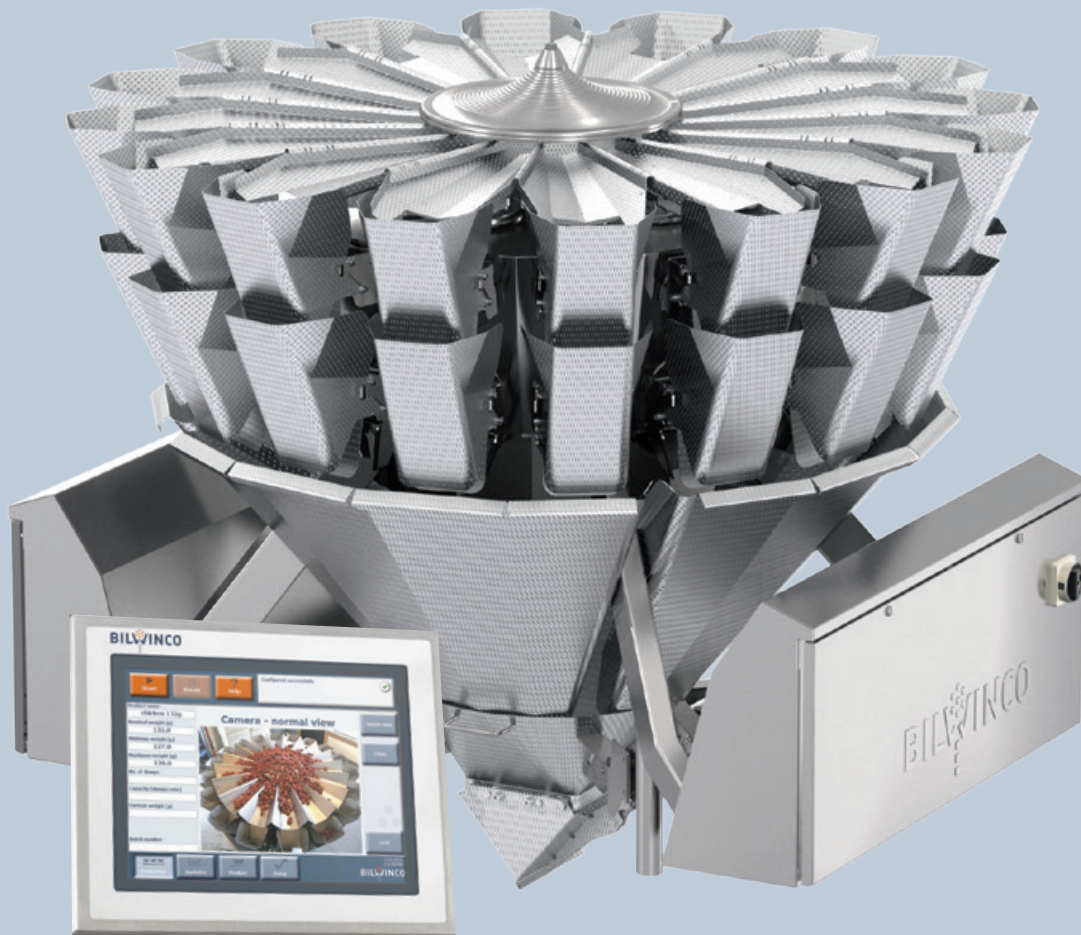

RW REVOLUTION WEIGHER

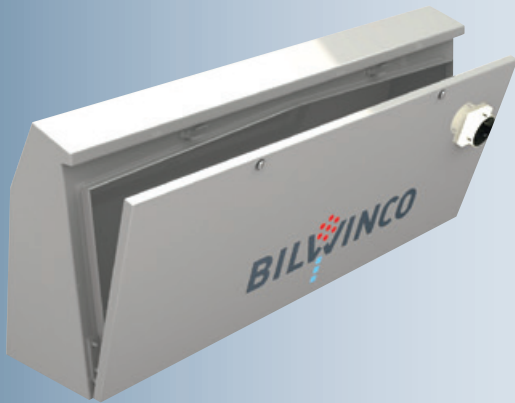

COMBINE UNIQUE DESIGN AND GREAT FUNCTIONALITY

Open just one hinged door and You have full access to the main scale control. The most hygienic multihead on the market, of course also include hygienic waterproof cabinets, even on the non wash-down versions. This ensures you no dust coming thru to the electronic components.

Reduce risk of caramelizing. When running sugar or sugared products, it is of high importance that the scale body is not heated by inner electronic components. Electronic components are kept away from the Bilwinco Revolution machine body.

BILWINCO – EASY OPERATION

The RW Revolution Series comes with the largest Touch Screen HMI on the market for Multihead Scales. The size makes it easy for the operators surveying the clear menus and operate the large buttons. The user-friendly 15" Screen features OEE readings (Operating Equipment Efficiency), Statistical data, Operator Settings and much more. Data is shown on-screen or sent to a USB stick or via Ethernet to other devices. Data can be displayed through performance graphs to help optimizing. Basically all historical data are logged. The control panel is cased in a smooth and easy to clean stainless steel IP65 rated frame, and for mounting in positions being most convenient for the operators. A very nice optional feature is the operator-time-saving integrated survey cam, making it possible to survey the top of the multihead from floor level - and from there even direct the cam and zoom in if required.



FULLY AUTOMATIC CONTROLLED VIBRATORS

High speed and high accuracy starts with the ability to transport the product perfectly. This machine starts out with basic default settings, but within few seconds the control has optimized the speed and performance automatically, which makes the job for the operator easy and the production managers happy. It is a skill Bilwinco has been known for, as the best in the market, since 1955. Every machine leaving the factory has gone through a custom and product dependent routine, securing ideal amplitude and frequency for the specific product and project requirements.



DIRECT WEIGHING GIVES YOU THE MOST ACCURATE AND FASTEST WEIGHING SYSTEM AVAILABLE

Weighing hoppers are attached directly to the load cells without the need of gaskets in between – this is called direct weighing and is the most direct way to read stable and reliable load signals. It is the "The Bilwinco way". Combine this with a robust scale body design and unique electronic weighing technology and software – and it all ensures you the best and most reliable accuracy ever. Should you accidentally brake the load cell, of course you should replace the load cell only, and nothing else.





- In some dry food applications, the product zone may need a full wash down on regular basis. Candies may generate a build-up and dried fruits may leave a sticky sugared surface at the end of the day. You can COP our product zones or wash them in our integrated wash stations right next to the scale.

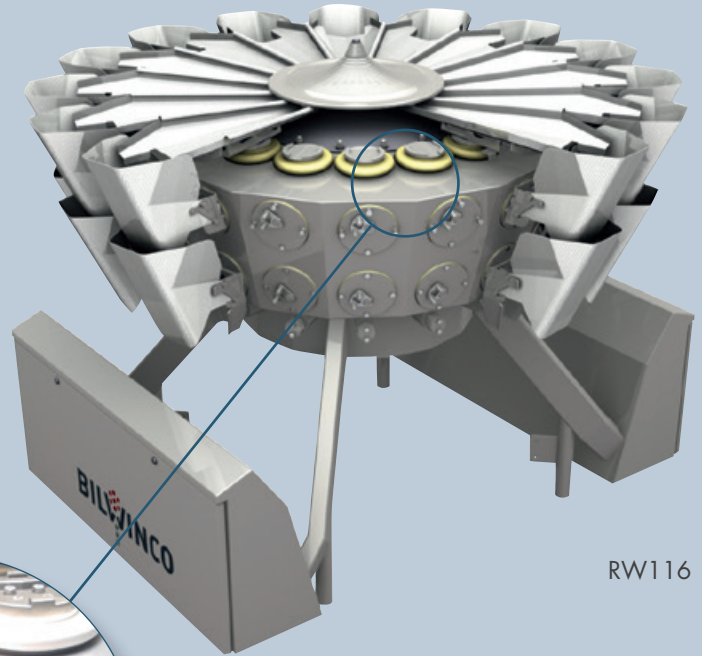

RW116

- Special features like our soft-drop can be integrated to soften the discharging of fragile cookies and candies. The compact scale design further offers less dropping and more sliding than others, and therefore we do handle your products more gently.

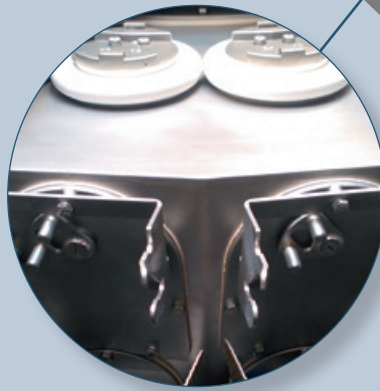

- An angled top being fully welded onto the sleek body, leads to no unhygienic edges or overlapping seams. Under the principle of "fix only what is broken", you can access or replace individual components.
- One actuator eg comes free by loosening just four bolts. This is part of the reason why this machine is the most economic machine to maintain on the market.

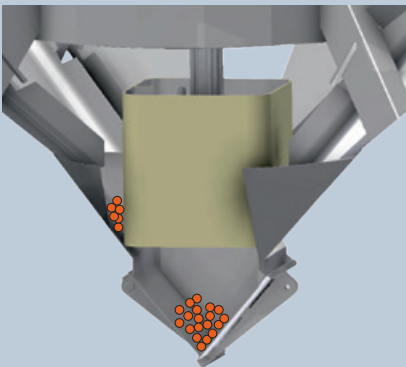

RW110

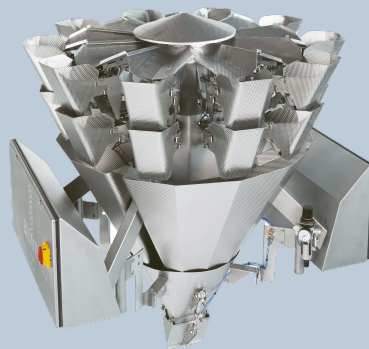

RW120

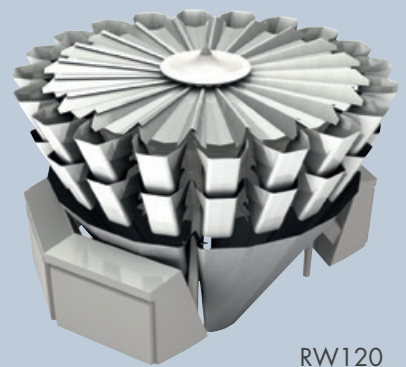

RW DRY SERIES

Technical details

| MODEL | RW110 | RW112 | RW116 | RW120 | RW212 | RW216 | RW220 | RW316 |
|-----------------------------------|------------------|------------------|------------------|------------------|------------------|------------------|------------------|------------------|
| Product Sizes (mm) | 2-130 | 2-150 | 2-130 | 2-130 | 2-180 | 2-180 | 2-180 | 5-240 |
| Bucket sizes (L) | 1-2 | 1-2-3 | 1-2 | 1-2 | 5 | 5 | 5 | 10 |
| Portion Volume (L) | 3-4 | 3-8 | 3-5 | 3-5 | 3-20 | 3-20 | 3-20 | 5-35 |
| Accuracy (g) | +/- 0,5-1 | +/- 0,5-1 | +/- 0,5-1 | +/- 0,5-1 | +/- 1-2 | +/- 1-2 | +/- 1-2 | +/- 1-3 |
| Capacity (ppm) | Up to 75 | Up to 90 | Up to 140 | Up to 200 | Up to 75 | Up to 100 | Up to 140 | Up to 65 |
| Dimensions (mm) | Ø 1394 H 1046 | Ø 1457 H 1167 | Ø 1494 H 1167 | Ø 1664 H 1206 | Ø 1895 H 1373 | Ø 2083 H 1373 | Ø 2409 H 1373 | Ø 2439 H 1707 |
| Weight (kg) | ~375 | ~440 | ~540 | ~660 | ~860 | ~1150 | ~1433 | ~1335 |
| High Power Vibrators | ● | ● | ● | ● | ● | ● | ● | ● |
| Linear Drive springless Vibrators | - | ○ | ○ | ○ | ○ | ○ | ○ | - |
| Pneumatic Actuators | ● | ● | ● | ● | ● | ● | ● | ● |
| Electrical Actuators | ○ | ○ | ○ | ○ | ○ | ○ | ○ | - |

● Standard

○ Option

* Since the leaflet was produced, both a RW114 and a RW124 edition has been developed, please contact our Sales Dept. for further details

We reserve the right to introduce design modifications without prior notice. Errors and omissions excepted.

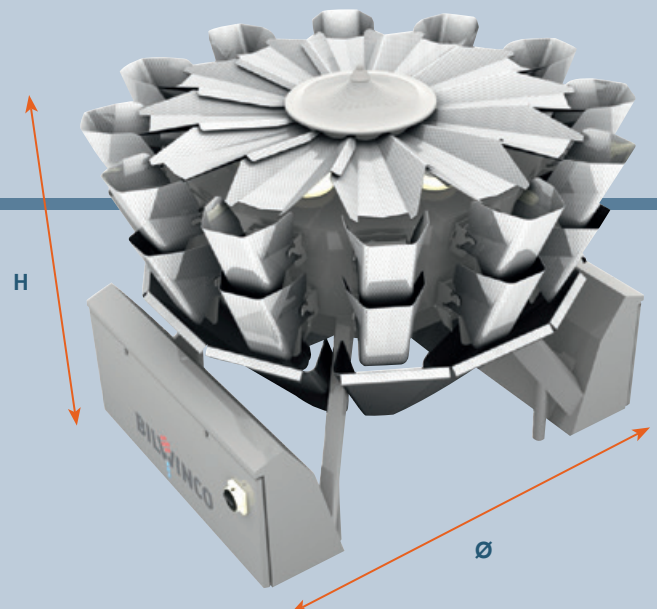

BILWINCO A/S
 Hedevej 3
 9800 Hjørring
 Denmark
 Tel: +45 86 51 06 66
 Email: info@bilwinco.com
 www.bilwinco.com

