

**COMPACT REVOLUTION – THE C SERIES**  
*The series of the new compact revolution multihead scale ensures smaller footprint, higher speeds and better performance.*

- **UNBREAKABLE LOAD CELLS** – the only multi-head scale on market offering such reliable concept!
- **UNBELIEVABLE LOW COST OF OWNERSHIP (COO)** – lowest on market, just a fact.
- **UNBEATABLE GIVEAWAY** – gasket free direct weighing with 25% less giveaway versus traditional multihead weighers.





## REVOLUTION WEIGHER – COMPACT

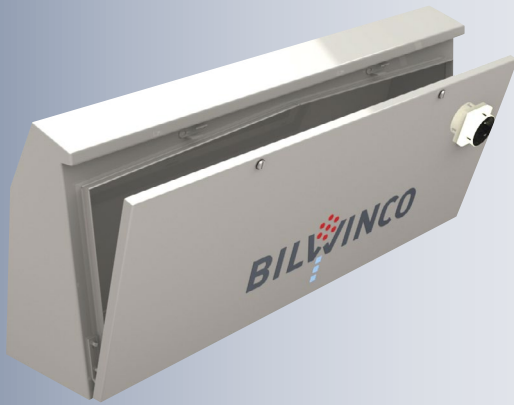

### COMBINE HYGIENIC DESIGN AND GREAT FUNCTIONALITY

Full and easy access to the main scale control is key for any customer. The most hygienic multihead on the market, of course also include hygienic waterproof cabinets. A small detail, like the door closes protected UNDER an angled roof, makes a big difference in the daily sanitation process. The IP67 waterproof scale is guaranteed for several daily sanitations. The scale is built on a fully welded and sleek body, with no unhygienic edges or overlapping seams. Scale is self-draining thru no-horizontal surface design.

### BILWINCO – EASY OPERATION

The Revolution Compact Series comes with the largest Touch Screen HMI on the market for Multihead Scales. Size matters. The user-friendly 15" Screen features OEE readings (Operating Equipment Efficiency), Statistical data, Help and Trouble Shooting Menus and much more. The HMI is cased in a smooth and easy to clean stainless steel IP65 frame. A very nice optional feature is the operator-time-saving camera, making it possible to survey the top of the multihead from floor level – and from there even direct the cam and zoom in if required.



### THE POWERFUL AND COMPACT C-SERIES

An overall compact design with new advanced self-tuning vibratory pans control ensures high speed weighing at unbeatable accuracy. The new control operates with higher resolution and 3 times faster processing speed. Smooth and accurate product flow to the double gate buckets at low drop heights, are just a few reasons why we do this so well. Bilwinco still offers the most powerful vibration technology since 1955 – this gives you fast and accurate dosing 24-7.

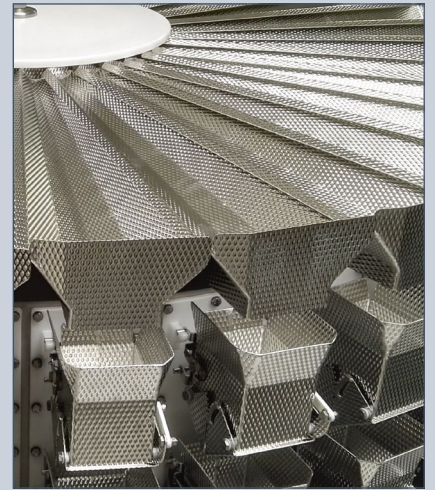

### NOTHING BUT THE BEST LOADCELLS ON MARKET

Tired of replacing load cells?  
No one else offers gasket free direct weighing with a robust 300% overload protection in all directions. Replacing load cells is basically history. All this keeps your uptime high while giveaway and cost of ownership is kept lowest ever.







**RELIABLE SCALE BUCKETS**

Buckets can be cleaned in place or can be removed for sanitation purposes and our buckets are therefore interchangeable and made in a robust stainless steel design. Buckets are operated by stepper motor actuators, but could also be pneumatically driven on request. The dual gated buckets are slightly larger than other similar compact scale buckets, offering several advantages in terms of product sizes and portion volumes.

**TRUE MULTIHEAD**

Each channel has its own pre-charge bucket and weighing bucket. At the end of the day it gives you less product build up, less buckets to keep clean and less product damage – compared to machines with additional combination buckets.

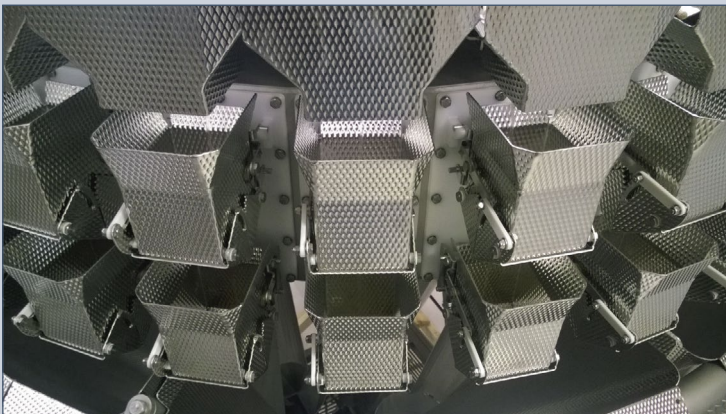

**CLEVER SCALE DESIGN KEEPS YOUR COSTS DOWN**

Under the principle of “fix only what is broken”, you can access or replace individual components at a fraction of similar top range multihead maintenance costs. This is part of the reason why this machine has such low cost of ownership

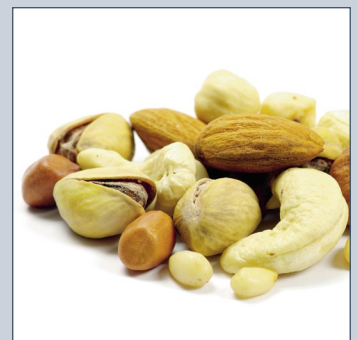
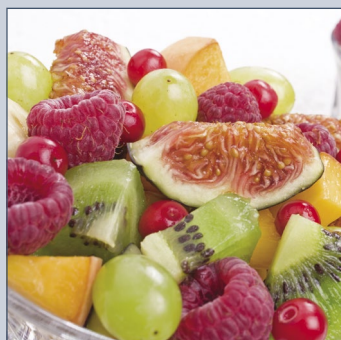

# RW WET & DRY

## Technical details

RW100 – Compact Series	RW124W-C	RW132W-C
Heads	24	32
Product Sizes (mm)	2-50	2-50
Bucket sizes (L)	0,8	0,8
Portion Volume (L)	1-4	1-5
Accuracy (g)	+/- 0,5-1	+/- 0,5-1
Capacity (ppm)	Up to 200	Up to 300
Diameter (mm)	Ø 1781	Ø 1924
Height (mm) excl discharge	H 1148	H 1310
Weight (kg)	~850	~1250
Mix & Split Options	1-2-3	1-2-3-4

We reserve the right to introduce design modifications without prior notice. Errors and omissions excepted.

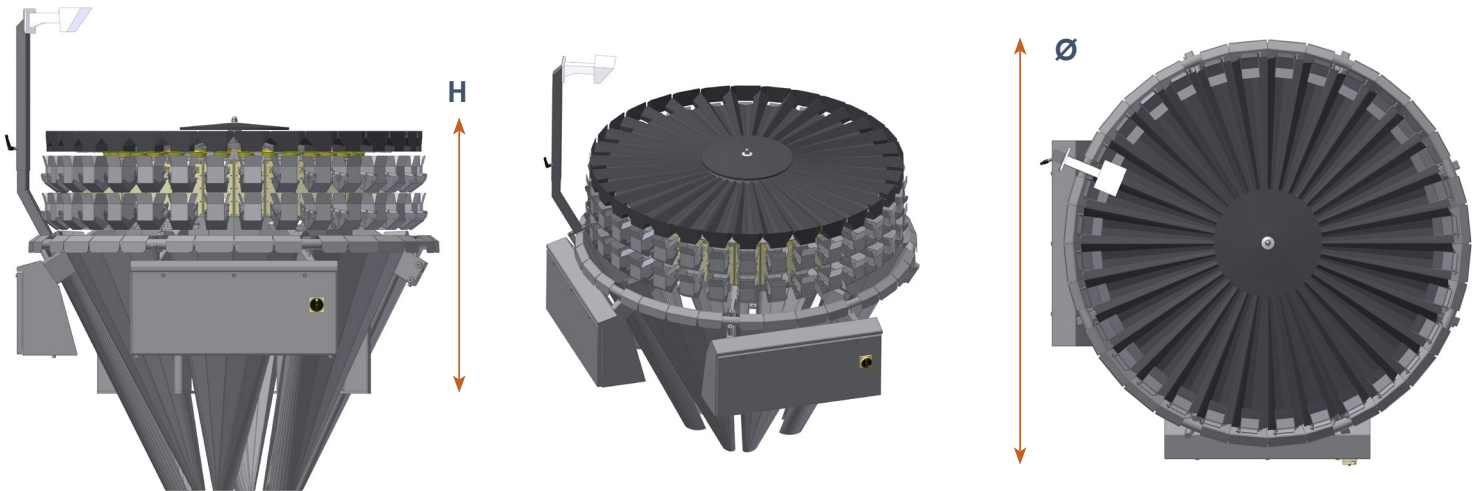

**BILWINCO A/S**  
**Hedevej 3**  
**9800 Hjørring**  
**Denmark**  
**Tel: +45 86 51 06 66**  
**E-mail: info@bilwinco.com**  
**www.bilwinco.com**

